



# *Operating instructions ENESKAsonic*





## Table of contents

<b>1</b>	<b>Notes about these instructions</b>	<b>4</b>
<b>2</b>	<b>Product overview</b>	<b>4</b>
<b>3</b>	<b>Parts supplied for an ENESKAsonic ultrasonic system.</b>	<b>4</b>
<b>4</b>	<b>Technical data for ENESKAsonic control unit.</b>	<b>5</b>
<b>5</b>	<b>Safety.</b>	<b>5</b>
	Intended use	5
	General safety instructions.	5
<b>6</b>	<b>Controls and indicators</b>	<b>6</b>
<b>7</b>	<b>The function of the signal sounds</b>	<b>7</b>
<b>8</b>	<b>Functions of the LED display strips</b>	<b>7</b>
<b>9</b>	<b>Function of the ventilation.</b>	<b>8</b>
<b>10</b>	<b>Calling up the menu and navigating</b>	<b>8</b>
<b>11</b>	<b>Start up</b>	<b>9</b>
	Replace the fuse (if necessary)	9
	Connecting a handpiece	9
	Mounting/changing the tool holder and tool	10
	Connecting the mains cable	10
	Switching the unit on	11
	Setting the language (if necessary).	11
<b>12</b>	<b>Connecting the foot pedal (optional).</b>	<b>11</b>
<b>13</b>	<b>Operation</b>	<b>12</b>
	Switching the unit on	12
	Selecting a handpiece	12
	Switching the handpiece on	12
	Choosing the power, BOOST function.	13
	Adjust the working point during operation (TUNE, if required).	13
	Stopping the handpiece.	14
	Switch the unit off.	14
<b>14</b>	<b>Testing the handpiece's function</b>	<b>14</b>
<b>15</b>	<b>Setting the timer</b>	<b>15</b>
<b>16</b>	<b>Calling up information about the unit</b>	<b>15</b>
<b>17</b>	<b>Setting the signal tone and LEDs</b>	<b>16</b>
<b>18</b>	<b>USB interface</b>	<b>16</b>
<b>19</b>	<b>Firmware update.</b>	<b>16</b>
	Doing a firmware update.	16
	Possible errors during a firmware update	17
<b>20</b>	<b>Maintenance, care and disposal</b>	<b>18</b>
<b>21</b>	<b>Troubleshooting and fixing faults</b>	<b>18</b>

**1**

**Notes about these instructions**

These operating instructions enable the operator to operate, care for and maintain the ENESKAsonic system correctly. These operating instructions are part of the system and must always be kept at hand at the place of use. If the ENESKAsonic system is passed on to a third party then these operating instructions must be passed on too.

Instructions which must be strictly observed to prevent hazards or damage are marked as follows:



**Warning!**

Warns of hazards that could result in serious injury or death.



**Caution!**

Warns of hazards that can lead to damage to objects.

For technical problems or other questions please contact our service department.

**2**

**Product overview**

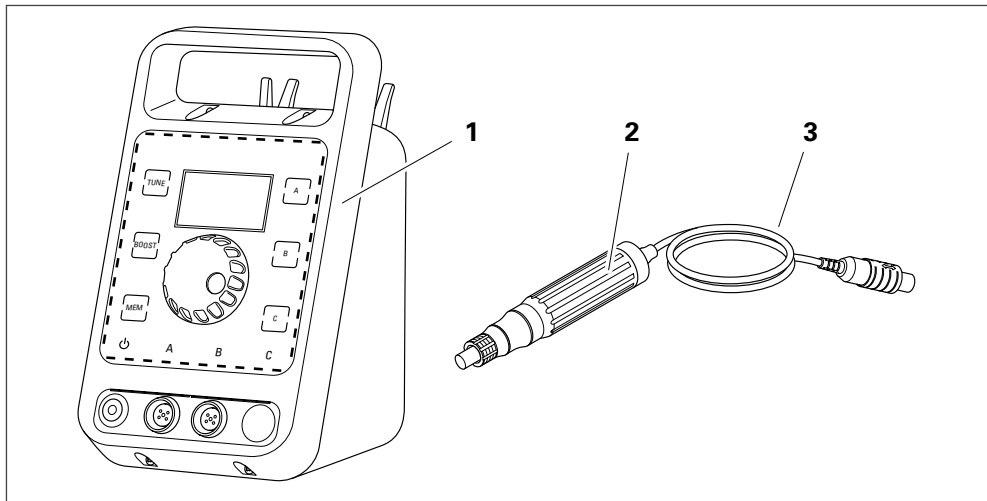

Fig. 1

1	ENESKAsonic control unit	3	Handpiece cable
2	Ultrasonic handpiece		

**3**

**Parts supplied for an ENESKAsonic ultrasonic system**

- 1 x ENESKAsonic control unit (order no. 0 012 001)
- 1 x JUS-50-ES handpiece (order no. 0 012 008)
- 1 x Standard handpiece holder, black (order no. 0 011 110)
- 1 x mains cable set for Germany, Switzerland, England and Europe (order no. 0 007 435-1)
- 2 x 4 A fuses (order no. 1 711 407-1) for 110 V use
- 1 x Allen key (order no. 0 006 304)
- 2 x open-end spanner (order no. 0 006 347)
- 1 x tool holder bore Ø 3 mm (order no. 0 006 306-E)
- 1 x tool holder slot width 1 mm (order no. 0 006 310-E)
- 1 x ENESKAsonic, starter set ceramic fibre file NEW Super Stone, 3 pieces in a box (order no. 0 012 007)
- 1 x ENESKAsonic, blade holder for sonic cutter (order no. 0 006 351)
- 1 x ENESKAsonic, graphic blades for Sonic-Cutter, PU=10 pcs (order no. 0 006 354)

**4**

## Technical data for ENESKAsonic control unit

Connections	<b>2 connections for ultrasonic handpieces</b>
Supply voltage	115 / 230 V, 50 / 60 Hz, 150 VA
Power consumption	max. 80 W
Frequency range	20–40 kHz
Power supply socket fuse	16 A
Dimensions (W x H x D)	135 x 235 x 200 mm
Weight	2.7 kg
Ambient conditions	0°C to +40°C 10% to 85% humidity
Noise pressure level	< 70 dB (A)
Permissible handpieces	JUS-45 PB-ES; 50 W, 22.5 kHz (40 µm) JUS-50 ES; 50 W, 22.5 kHz (40 µm)
Approved threaded connection for the handpiece	Thread M6/FINE (M6 x 0.9)
USB type A interface	Charging voltage 5 V at 1.8 A

The manufacturer's logo, type designation, CE mark and serial number are located on the back of the control unit and on the housing of the handpiece.

A complete overview of accessories can be found in the joke catalogue for surface treatment, in the "Drive systems and handpieces" chapter.

The list of spare parts and the declaration of conformity are available online at [www.joke-technology.de](http://www.joke-technology.de).

**5**

## Safety

### Intended use

ENESKAsonic systems are designed exclusively for removing material, deburring, lapping and polishing with a straight motion.

ENESKAsonic systems may only be used with approved components and accessories (see chapter 3, Technical specifications).



**Only insert tools in the clamp in "clamp" mode, since clamped tools may be destroyed in "unclamp" mode.**

ENESKAsonic control units may only be used as described in these operating instructions. Any other use or use going beyond this is considered improper use. The manufacturer will not be liable for damage resulting from improper use.

### General safety instructions

To avoid danger to persons and material damage, ALWAYS observe the following safety instructions:

- Only use ENESKAsonic systems in technically perfect condition.
- Always place the ENESKAsonic system control unit on a safe, non-slip surface and protect it from contact with liquids.
- When working with the ENESKAsonic system, always wear safety glasses, gloves and hearing protection.
- Never disconnect the handpiece from the control unit while it is switched on!
- Always switch off the control unit when the system is not in use.
- Always ensure sufficient extraction of any dust particles that may arise.
- Always make sure that the device's ventilation slots are free (see also chapter 9).
- Do not leave the ENESKAsonic system unattended when switched on.

- Immediately rectify faults in the ENESKAsonic system yourself or have them rectified in accordance with these instructions.
- Do not make any changes, additions or modifications to the individual components of the ENESKAsonic system.
- Never immerse the individual components of the ENESKAsonic system in water or other liquids.
- Do not use the system outdoors.

## 6 Controls and indicators

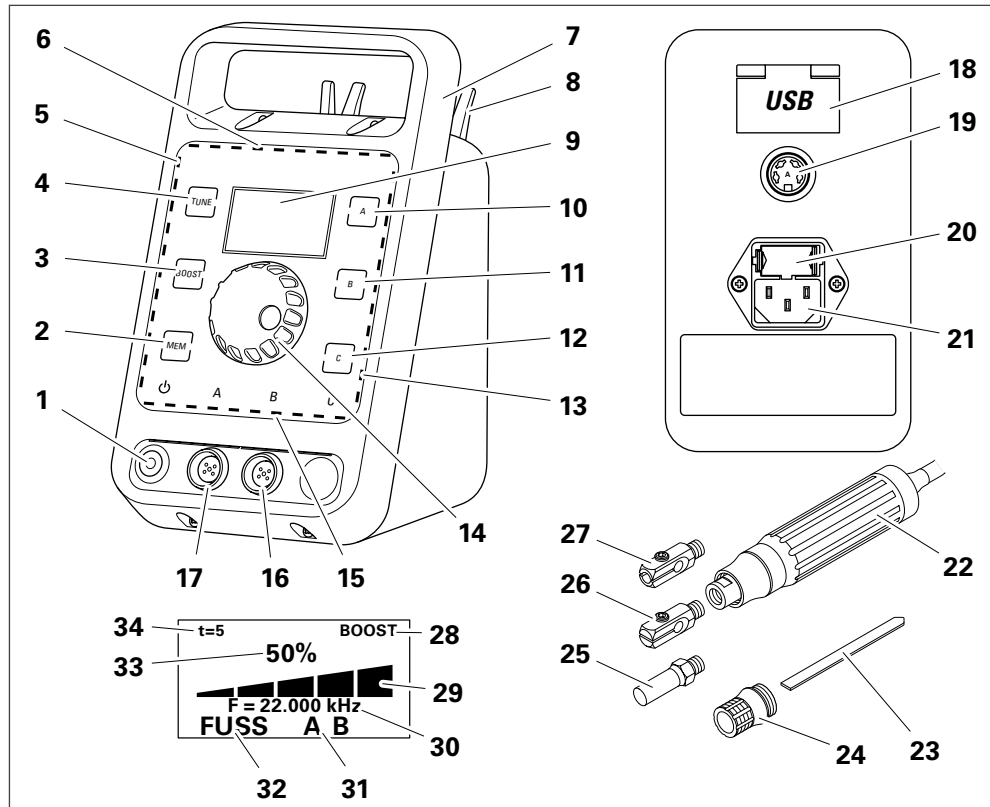
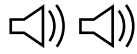

Fig. 2

1	Power switch	18	USB connection with dust flap
2	MEM button	19	Foot pedal connection
3	BOOST button	20	Fuse
4	TUNE button	21	Mains plug connection
5	Left LED strip	22	Ultrasonic handpiece
6	Upper LED strip	23	Tool (flat)
7	Carrying handle	24	Protective cap
8	Handpiece rest	25	Protective pin
9	Display	26	Tool holder for flat tools
10	Channel button [A]	27	Tool holder for round tools
11	Channel button [B]	28	Indicator for the BOOST function
12	Button [C]	29	Power indication as bars
13	Right LED strip	30	Frequency display (kHz)
14	Rotary control knob	31	Indicator for handpiece inserted
15	Lower LED strip	32	Indicator for foot pedal inserted
16	Connection B	33	Power indicator in %
17	Connection A	34	Display of timer function

## 7 The function of the signal sounds



2 brief sounds

- After TUNE process: Device is ready to use
- Settings accepted e.g. after saving



1 long sound

- Device error or faulty operation  
Troubleshooting or device restart required

## 8 Functions of the LED display strips

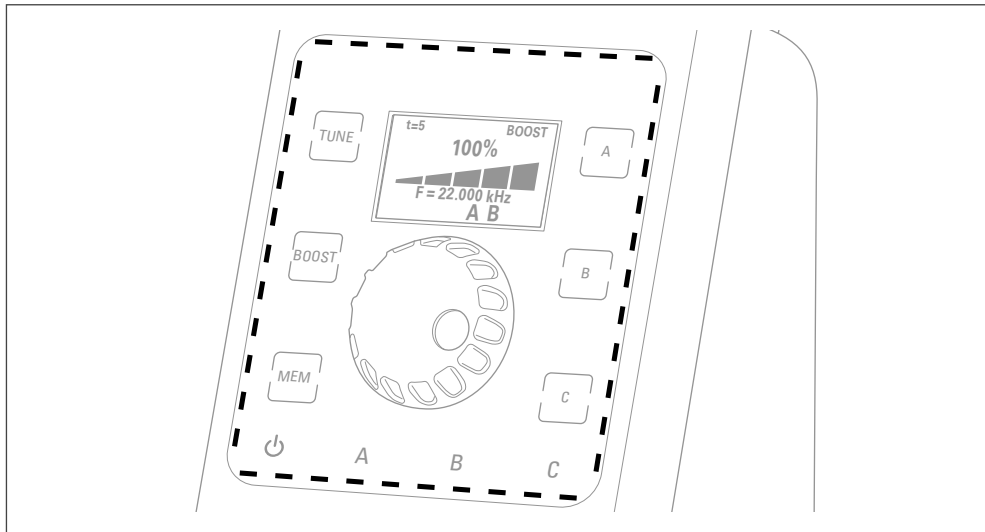

Fig. 3

LED strip	Colour	Type of display	Meaning
Top	Blue	Pulsing	Handpiece is connected
	White	Lights	TUNE in progress
	Blue-white	Movement towards the centre	Handpiece is switched on
Bottom	Green	Lights (2 LEDs, central)	Optimum working point
	Green	Lights (2 LEDs, not central)	Optimum working point has shifted
	Yellow to red	LED moves to left and right	Tool cannot be aligned
	Colourful	LED moves to left and right	The device is looking for the working point
Right	--	--	--
Left	White	Drop-down effect:	Idling, timer is expiring
Top,, bottom	Red	Lights	Device error or faulty operation
	Red	Lights and buttons flash simultaneously	Serious device fault or dangerous operating error, restart required
All	White (right, left), Blue (top, bottom)	Lights	Important information in the display
	Colourful	Flashing and motion	Device starts or animation is running

## 9 Function of the ventilation

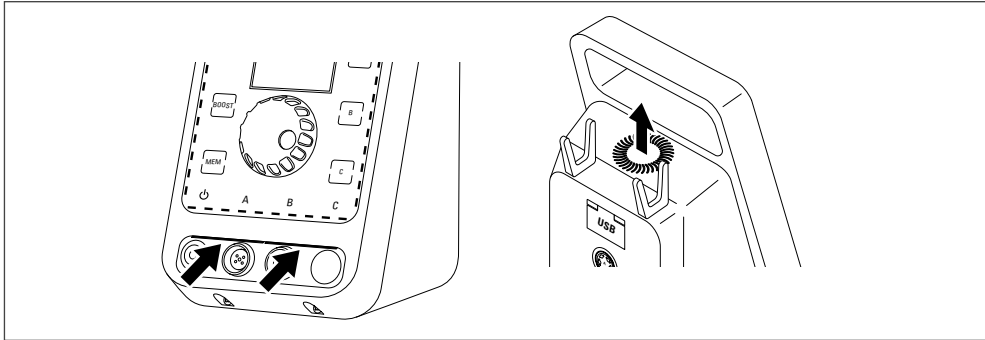

Fig. 4

The ventilation serves to prevent overheating. Fresh air is supplied through the front slots. Heated air is discharged from the top of the control unit. An integrated carbon filter retains the moisture.

Always keep the unit's ventilation slots clear to prevent damage from overheating.

## 10 Calling up the menu and navigating

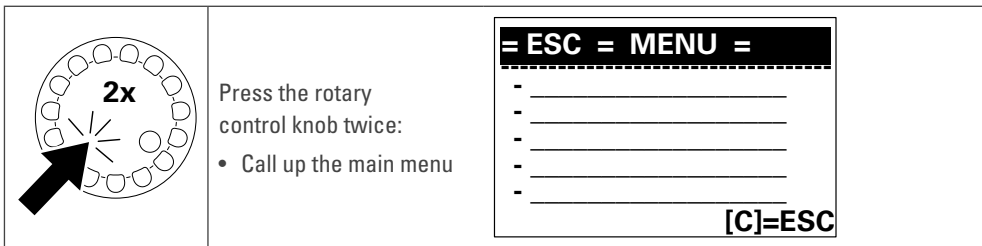

Fig. 5

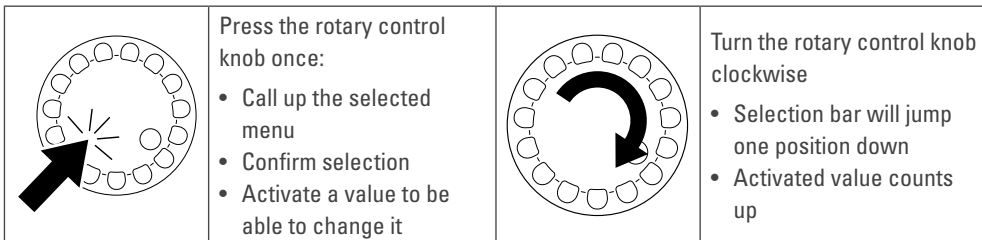

Fig. 6

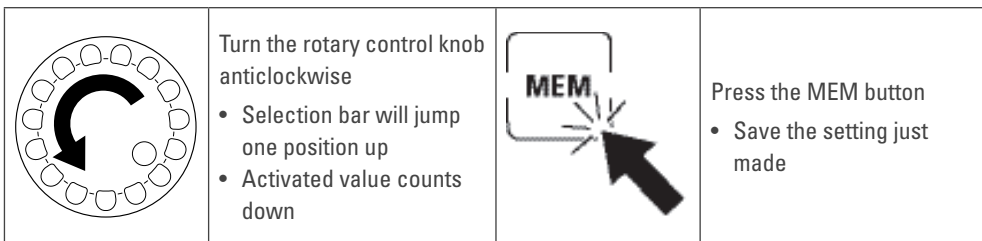

Fig. 7

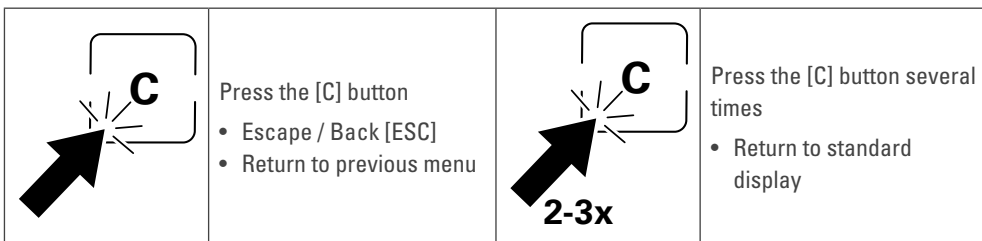

Fig. 8

11

## Start up

### Replace the fuse (if necessary)

The control unit is factory set to 230 V and equipped with two 2 A fuses. One of these two is intended to be a spare. Two 4 A fuses are also included.



#### Caution!

Only use the following fuses:

- Microfuse 5 x 20 mm, T4L 250 V for 115 V
- Microfuse 5 x 20 mm, T2L 250 V for 230 V

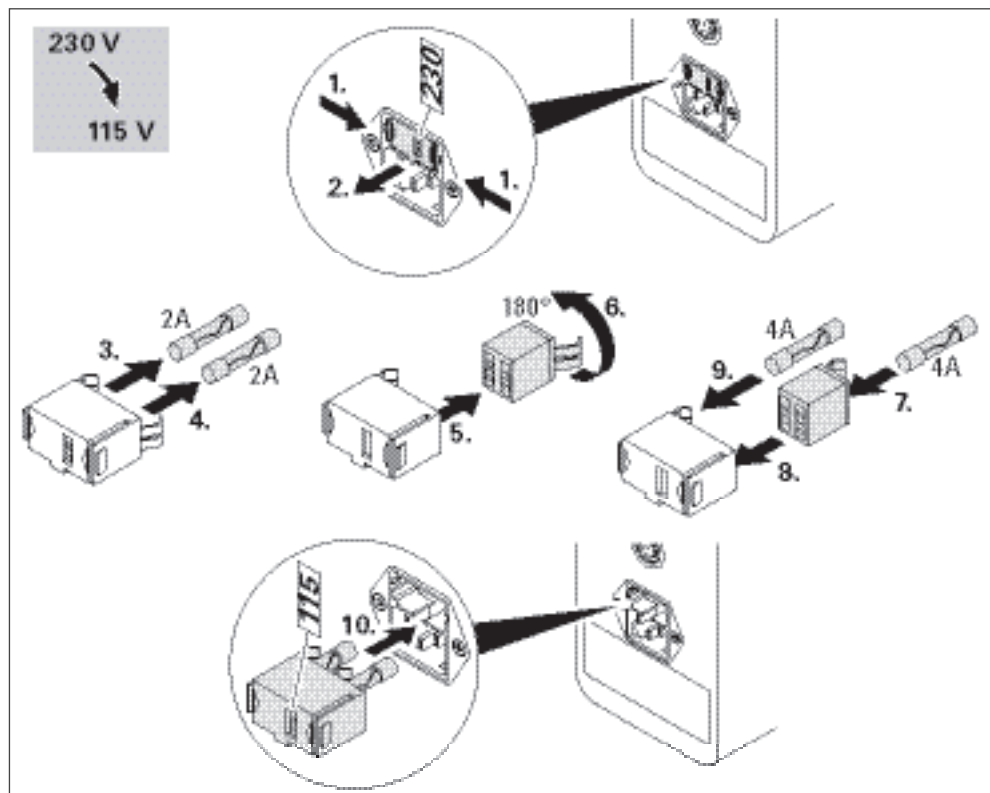

Fig. 9

### Connecting a handpiece



#### Caution!

Always plug the cable into the control unit's socket so that the double arrow on the connection cable and the guide strip of the protective cap point towards the white arrow on the connection socket. Do not damage the contacts while doing that!

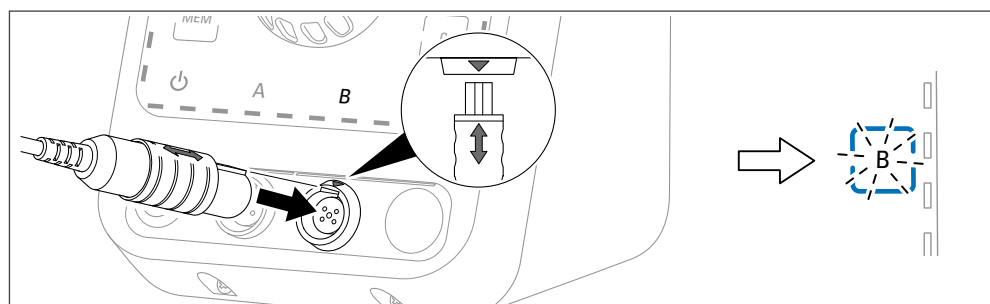

Fig. 10



## Mounting/changing the tool holder and tool



### Warning!

To avoid injuries caused by the tool vibrating unintentionally, only connect or change tools when the control unit is switched off.



### Warning!

To avoid injury from tools coming loose, always tighten the tools carefully and regularly check the fit of the tool.



### Caution!

To avoid damage to the components,

- thoroughly clean all parts before installing them and
- Only use tools and adapters with a M6/FINE (M6 x 0.9) thread.



Only tools with fixed thread connections may be operated at the "Unclamp" power setting. Only use tools operated in tool holders (e.g. ceramic fibre files) at the "Clamp" power setting. During use with an adapter, a loss of performance is to be expected.

#### Tool holder:

##### Bore-Ø

Ø 2 mm  
Ø 3 mm  
Ø 3.3 mm

##### Order no:

0 006 305  
0 006 306-E  
0 006 307

##### Slit width

0.5 mm  
0.8 mm  
1.0 mm  
2.0 mm  
3.0 mm

##### Order no:

0 006 308  
0 006 309  
0 006 310-E  
0 006 311  
0 006312

#### Tool:

Order no: 0 006 304-T

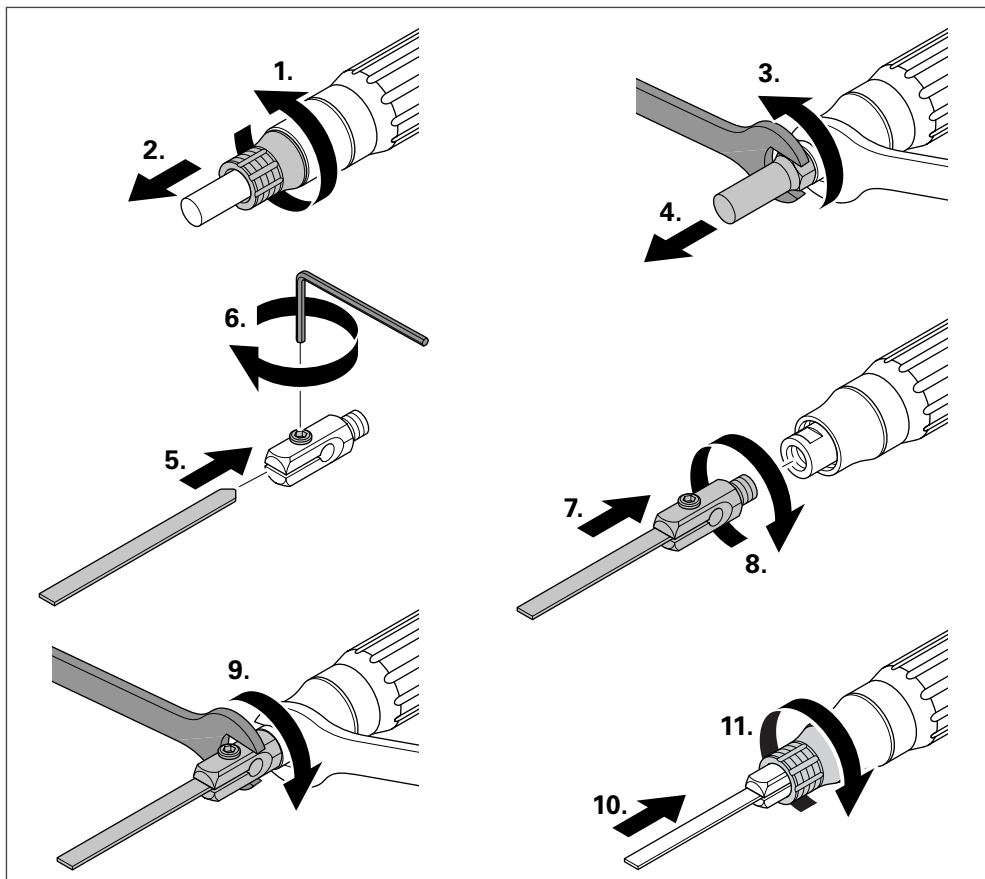

Fig. 11

## Connecting the mains cable

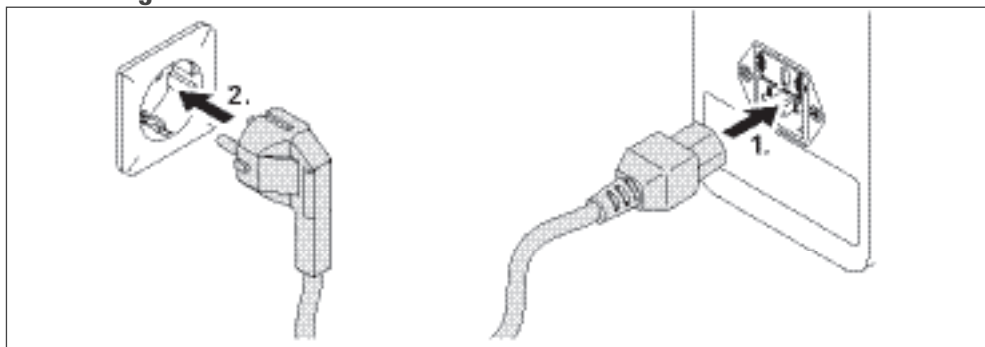

Fig. 12

**Switching the unit on**

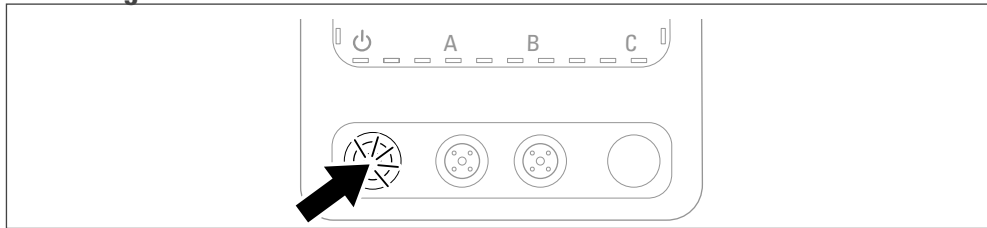

Fig. 13

**Setting the language (if necessary)**

Step 1	Step 2	Step 3	Step 4
<p>Call up the main menu</p>	<p>Select "Sprache/Language"</p> <pre> = ESC = MENU = - Sprache/Language - Timer - G-Info - Summer+LED - Firmware Update [C]=ESC                     </pre>	<p>Choose the language and save your choice</p> <pre> = ESC = Sprache = &gt; Deutsch English Francais [MEM]=SAVE [C]=ESC                     </pre>	<p>Back to the standard display</p>

**12 Connecting the foot pedal (optional)**

With a foot pedal the handpiece can be switched on and off with the foot during operation.

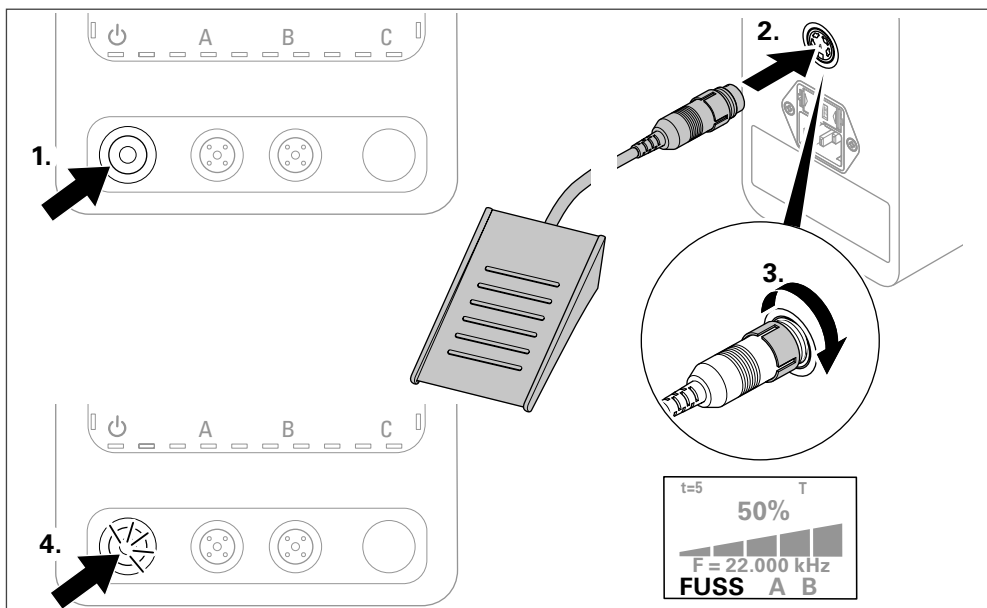

Fig. 14

### 13 Operation

While you are working, the system automatically determines the required power and adjusts it accordingly.

If an adapter is used, power may be lost.

#### Switching the unit on

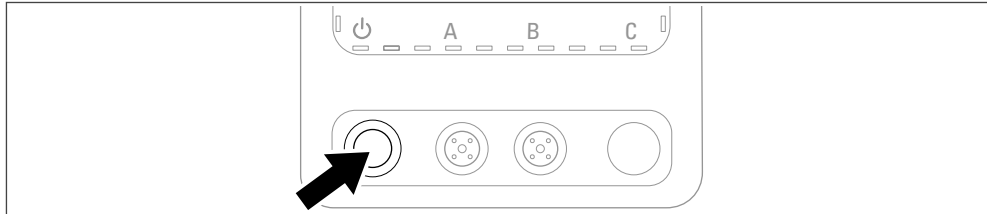

Fig. 15

#### Selecting a handpiece

Several handpieces can be connected to the control unit at the same time, but only one handpiece can be used at a time.

The handpiece that was last connected to or was used with the control unit will automatically be selected. The channel button A or B belonging to this handpiece will flash. If necessary, press the other button to select the other channel on the control unit.

#### Switching the handpiece on



##### Caution!

To avoid damage to the device,

- equip the handpiece with a tool or protective pin before switching it on and do not work with the tool until the AUTO TUNE operation has been completed.

The system automatically determines the required frequency during the AUTO-TUNE procedure.

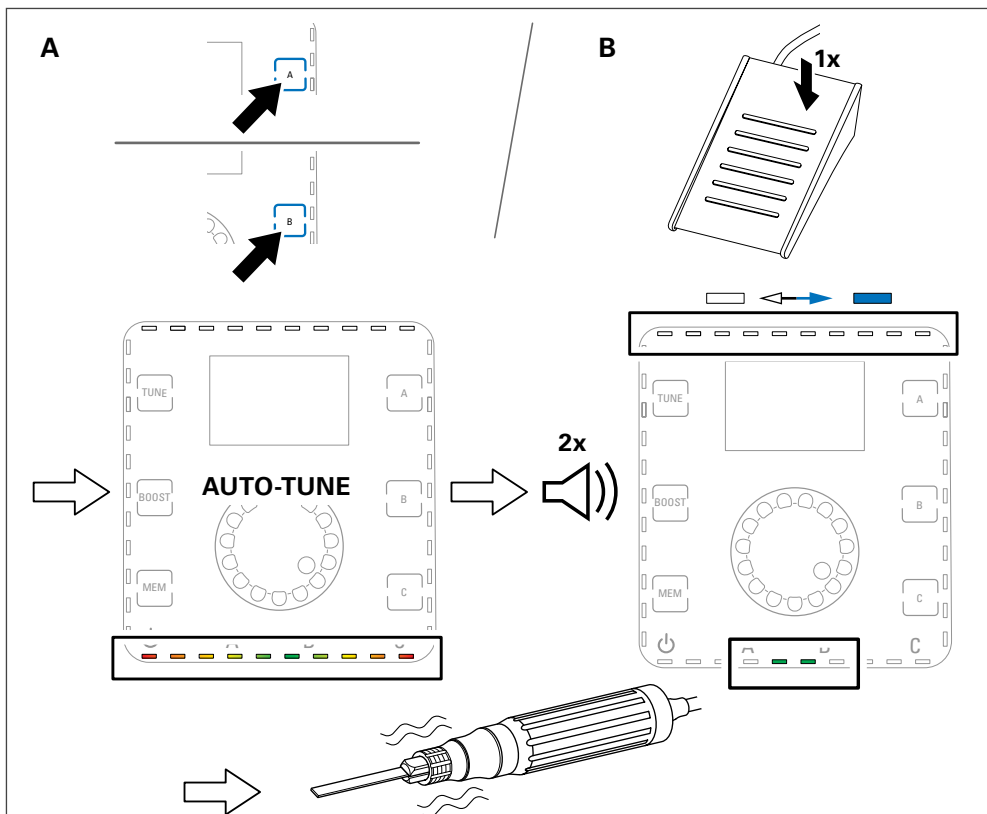
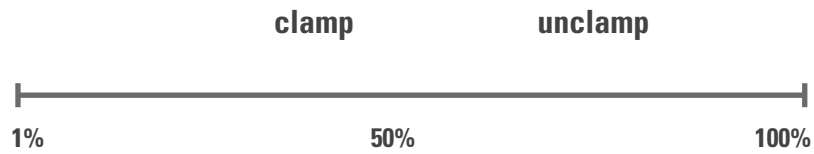

Fig. 16

## Recommended power stage



Material	Dimensions	Recommended tool length	Recommended setting	
			clamp	unclamp
Wood, hard	3 x 6 mm	15 - 35 mm	20 - 40%	
	Ø 3 mm	15 - 40 mm	20 - 40%	
Brass	2 x 10 mm	15 - 30 mm	20 - 40%	
	Ø 3 mm	15 - 30 mm	20 - 40%	
Ceramic fibre files	Ø 3 mm	15 - 45 mm	50 - 60%	
		> 60 mm	50 - 60%	
	1 x 4 mm	15 - 45 mm > 60 mm	50 - 60% 50 - 60%	
	1 x 6 mm	15 - 45 mm	50 - 60%	
		> 60 mm	50 - 60%	
Diamond files sintered (3 mm shaft)	Ø 3 x 45 mm	95 mm	50 - 60% 50 - 60%	
	6 x 3/0 x 15 mm konisch	55 mm		
Diamond file, sintered with connecting thread	Ø 2 x 8 x 40 mm	40 mm		
	4 x 1 x 16 mm	45 mm		
	5 x 1 x 40 mm	140 mm		
Diamond file, galvanic, with M 4 thread	5 x 1 x 9 mm	40 mm		80%
Diamond file, galvanic, with M 6 thread	6 x 1,5 x 25 mm	40 mm		90%



The settings given in the table are only guidelines. With installed tools, always start with a lower output and carefully adjust upwards. Particularly pay attention to heating of the tool and tool adapter. The tools may be destroyed if the temperature is too high.

The tools must be cleaned before each installation. With clamped tools, attention must particularly be paid to perfect seating of the tools in the holder. The tools must be positioned over their entire length in the clamping area.

## Choosing the power, BOOST function



### Caution!

To avoid damage to tools or the workpiece:

- always start with a low power setting (1%) and then adjust the power as required, and
- for high power settings (> 50%), only use tools designed for this purpose!

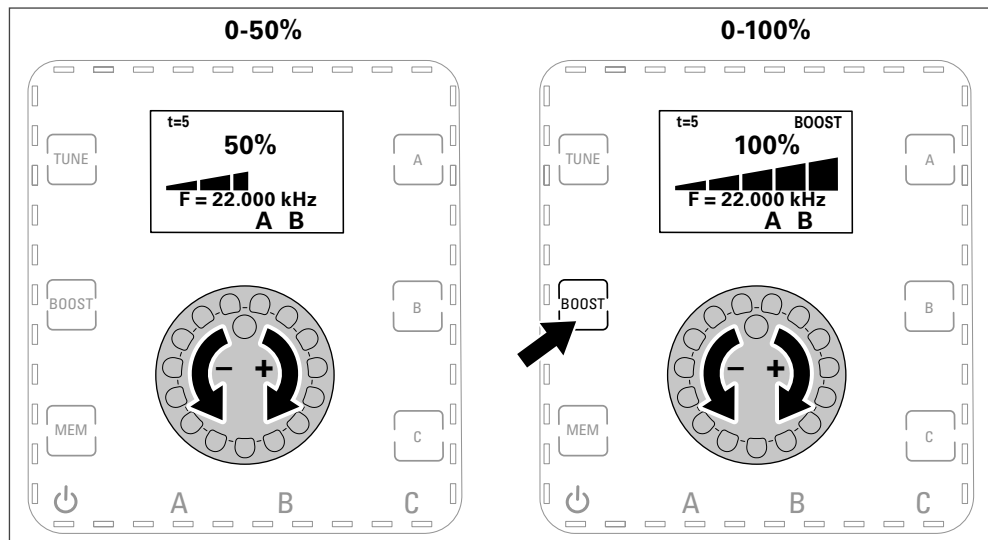

Fig. 17

## Adjust the working point during operation (TUNE, if required)

The working point can shift at different power settings or wander away from the determined operating point due to heating and wear of the tool. This is indicated in the lower LED strip by the two green LEDs moving away from the centre. The TUNE function allows readjustment during the working process.



### Caution!

To avoid damage to the unit or the tool,

- do not work with the tool while the TUNE operation is in progress.

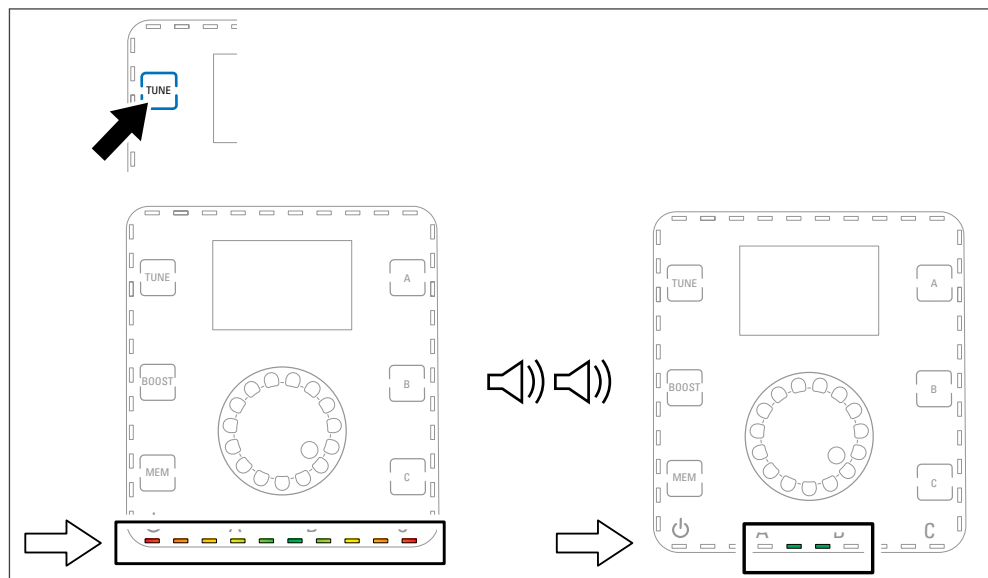

Fig. 18

## Stopping the handpiece

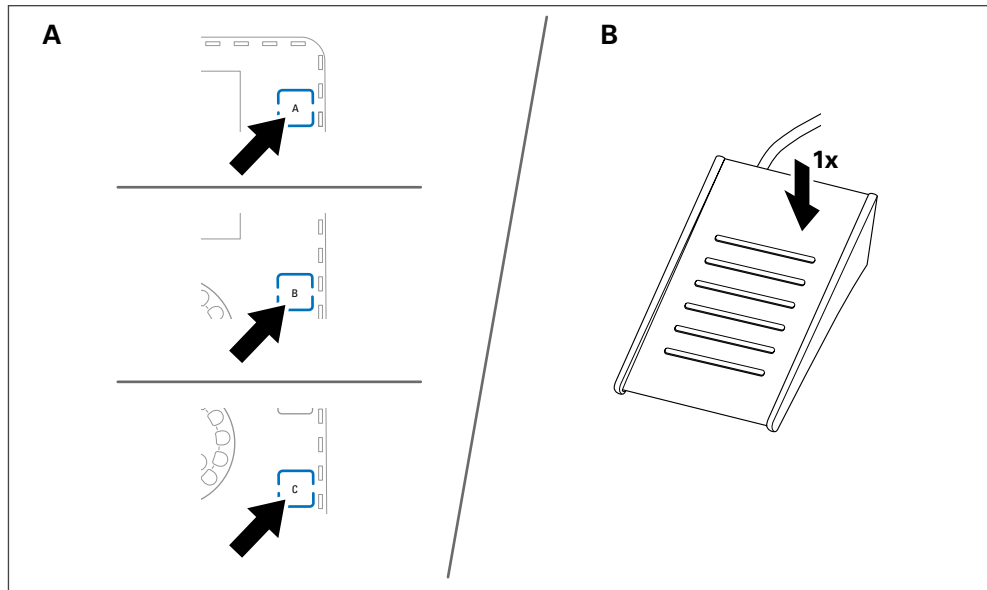

Fig. 19

## Switch the unit off

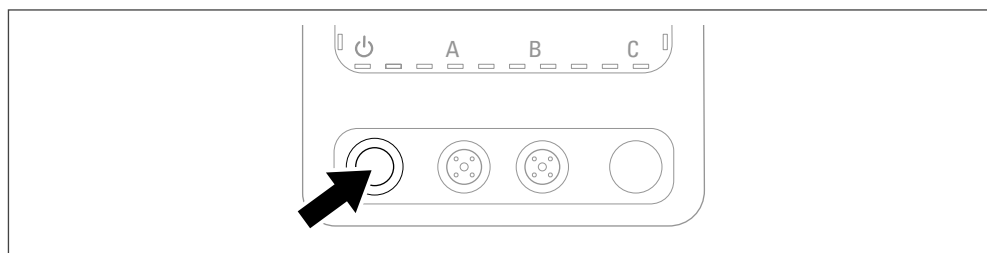

Fig. 20

## 14 Testing the handpiece's function

To check the correct function of the handpiece in the event of a malfunction, carry out the following test:

- » Mount the protective pin (see fig. 2, item 25).
- » Switch the handpiece on at the lowest power level (1%).
- » Immerse the tip of the protective pin briefly in water to wet it.
- » Turn the power up to 100% with the rotary control knob: At about 80%, the water drop should atomise as a cloud.
- » If this test is not successful, the handpiece is faulty. Contact joke service

## 15 Setting the timer

As soon as a handpiece runs without load, a timer will count down and the left LED bar will show a drop-down effect. The handpiece will switch off as soon as the set time has elapsed. The factory setting is five minutes.

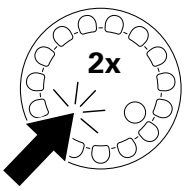
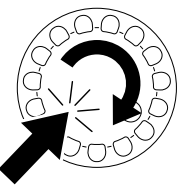
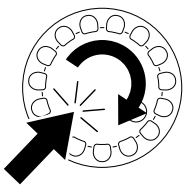
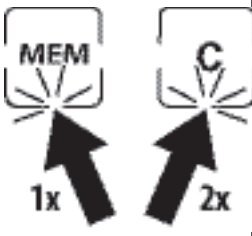
Step 1	Step 2	Step 3	Step 4
 <p>Call up the main menu</p>	 <p>Selecting a timer</p> <div style="border: 1px solid black; padding: 5px; margin-top: 10px;"> <p>= ESC = MENU =</p> <p>- Sprache/Language</p> <p>- Timer</p> <p>- G-Info</p> <p>- Summer+LED</p> <p>- Firmware Update</p> <p style="text-align: right;">[C]=ESC</p> </div>	 <p>Activate "Time in minutes" and set a time</p> <div style="border: 1px solid black; padding: 5px; margin-top: 10px;"> <p>= ESC = Timer =</p> <p>Leerlauf-Abschaltung</p> <p>Zeit in Minuten: X</p> <p>[MEM]=SAVE [C]=ESC</p> </div>	 <p>Save and return to the standard display</p>

## 16 Calling up information about the unit

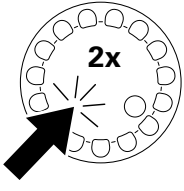
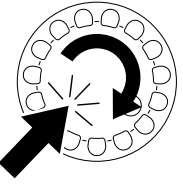
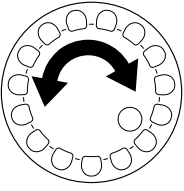
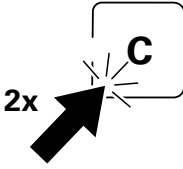
Step 1	Step 2	Step 3	Step 4
 <p>Call up the main menu</p>	 <p>Select "G-Info"</p> <div style="border: 1px solid black; padding: 5px; margin-top: 10px;"> <p>= ESC = MENU =</p> <p>- Sprache/Language</p> <p>- Timer</p> <p>- G-Info</p> <p>- Summer+LED</p> <p>- Firmware Update</p> <p style="text-align: right;">[C]=ESC</p> </div>	 <p>Displaying version information and operating hours</p> <div style="border: 1px solid black; padding: 5px; margin-top: 10px;"> <p>= ESC = G-Info =</p> <p>SW-DISPLAY: V</p> <p>HW-DISPLAY: V</p> <p>SW-POWER: V</p> <p>SW-POWER: V</p> <p style="text-align: right;">[C]=ESC</p> </div>	 <p>Back to the standard display</p>

## 17 Setting the signal tone and LEDs

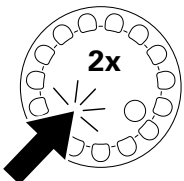
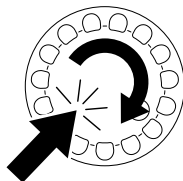
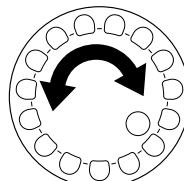
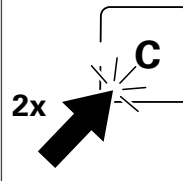
Step 1	Step 2	Step 3	Step 4
 <p>Call up the main menu</p>	 <p>Select "Buzzer + LED"</p> <div style="border: 1px solid black; padding: 5px; margin-top: 10px;"> <p>≡ ESC ≡ MENU ≡</p> <ul style="list-style-type: none"> <li>- Sprache/Language</li> <li>- Timer</li> <li>- G-Info</li> <li><b>- Summer+LED</b></li> <li>- Firmware Update</li> </ul> <p style="text-align: right;">[C]=ESC</p> </div>	 <p>Make your settings</p> <div style="border: 1px solid black; padding: 5px; margin-top: 10px;"> <p>≡ ESC ≡ Summer+LED ≡</p> <ul style="list-style-type: none"> <li>- LCD-Kontrast _____</li> <li>- Summer _____</li> <li>- LED Helligkeit _____</li> <li>- DEMO Anzeige _____</li> </ul> <p style="text-align: right;">[C]=ESC</p> </div> <ul style="list-style-type: none"> <li>Setting the contrast of the display</li> <li>Switching the signal tone on/off</li> <li>Setting the brightness of the LED signal strips</li> <li>Demonstrate the LED strips</li> </ul>	 <p>Back to the standard display</p>

## 18 USB interface

The USB interface on the rear of the device (see fig. 2) can be used, for example, as a connection for a USB LED spotlight for workplace lighting.

It is also used to upload new firmware and for service purposes.

If the USB interface is not in use, leave the dust cap closed.

## 19 Firmware update

### Doing a firmware update

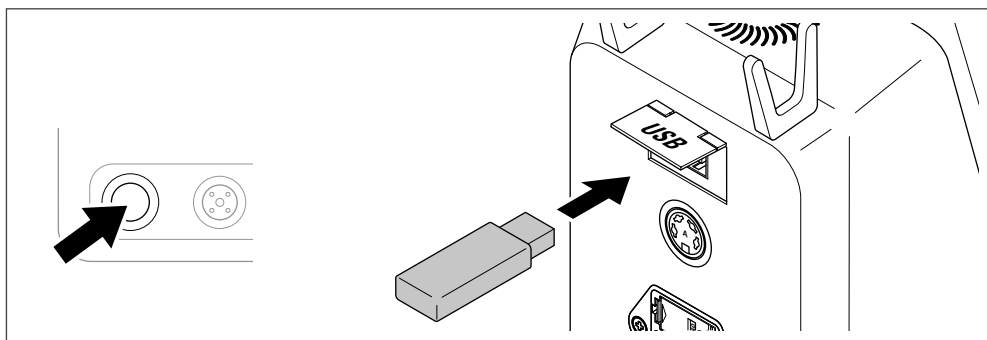

Fig. 21



- » Press the rotary control knob, keep pressing it and switch on the control unit. Keep pressing the knob until the "Load indicator" appears on the display. Then release the rotary control knob. The update will now be automatically installed.

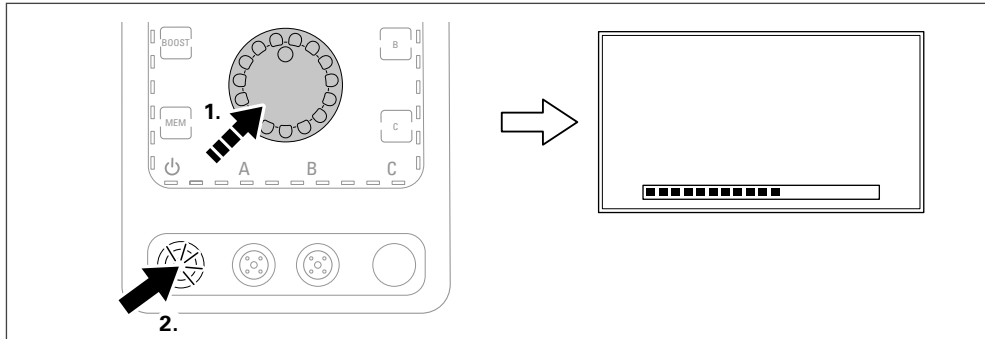

Fig. 22

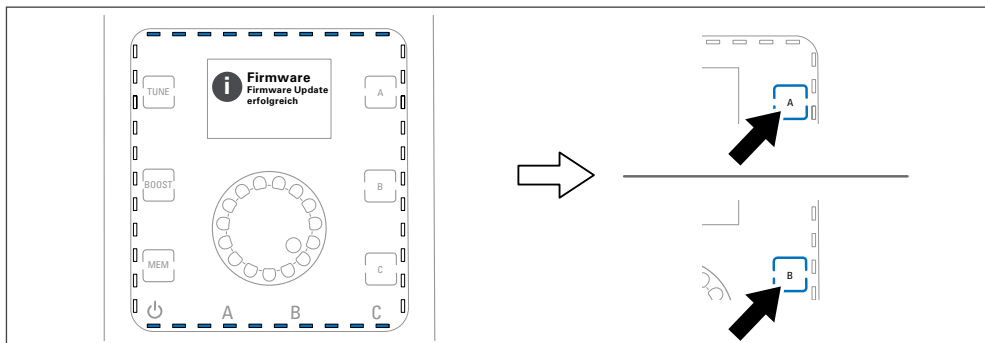

Fig. 23

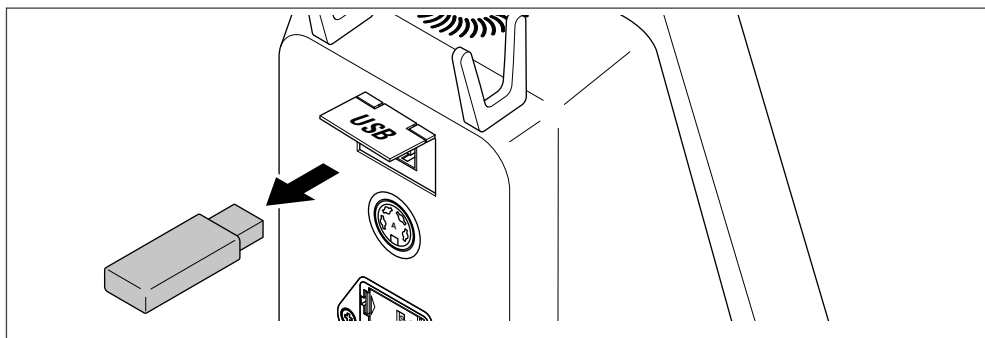

Fig. 24

### Possible errors during a firmware update

Error code in the display	Explanation	Remedy
1	General error (e.g. USB stick removed too soon)	<ul style="list-style-type: none"> <li>Restart control unit and try the update again.</li> <li>If the update still fails, contact joke service.</li> </ul>
3 / E	USB stick not recognized or data error	
9	Data on the USB stick is invalid or unreadable.	
B	Update not possible (e.g. due to wrong software version)	

20

## Maintenance, care and disposal

The control unit should be serviced once a year by joke Service.

The handpiece requires no service.

All components should only be cleaned with a dry, soft cloth.

Dispose of all components properly and do not put them into household waste under any circumstances.

21

## Troubleshooting and fixing faults

Error message	Cause	Remedy
<b>ERROR</b> The handpiece must never be removed during operation!	<ul style="list-style-type: none"> <li>Serious system fault: A handpiece was removed from the control unit while it was switched on. This can destroy the device.</li> </ul>	<ul style="list-style-type: none"> <li>Restart the system.</li> <li>If the error persists, contact joke service.</li> </ul>
<b>WARNING</b> Do not plug anything in during operation! Risk of destruction!	<ul style="list-style-type: none"> <li>One handpiece or foot pedal was connected to or removed from the control unit while the other handpiece was switched on. This can destroy the device.</li> </ul>	<ul style="list-style-type: none"> <li>Acknowledge the error with the handpiece button A or B and continue working.</li> </ul>
<b>WARNING</b> TUNE failed	<ul style="list-style-type: none"> <li>Tool cannot be tuned (working point cannot be found).</li> </ul>	<ul style="list-style-type: none"> <li>Acknowledge the error with the handpiece button A or B.</li> <li>Check whether the tool may be used with the ENESKAsonic system.</li> <li>Correct that the tool and the tool holder are correctly seated. The tool must not be mounted too tightly or too loosely. There must also be no debris in the tool holder.</li> <li>Check tool and tool holder for damage.</li> <li>Start the TUNE operation manually with the TUNE button.</li> <li>Test the function of the handpiece (see chapter 15).</li> <li>If the error cannot be corrected, contact joke service.</li> </ul>
<b>WARNING</b> Overload	<ul style="list-style-type: none"> <li>The control unit has been overloaded.</li> </ul>	<ul style="list-style-type: none"> <li>Acknowledge the error with the handpiece button A or B and continue working with reduced power.</li> </ul>
<b>WARNING</b> Cool down	<ul style="list-style-type: none"> <li>The control unit has been overheated.</li> </ul>	<ul style="list-style-type: none"> <li>Acknowledge the error with the handpiece button A or B and continue working with reduced power.</li> <li>Keep the ventilation slots clear and unobstructed.</li> </ul>
<b>WARNING</b> Working point	<ul style="list-style-type: none"> <li>The working point could not be readjusted automatically during operation.</li> </ul>	<ul style="list-style-type: none"> <li>see "Tool fault"</li> </ul>
<b>200 ... 208</b>	<ul style="list-style-type: none"> <li>Serious system fault:</li> </ul>	<ul style="list-style-type: none"> <li>Try to restart the system.</li> <li>If the error persists, contact joke service.</li> </ul>

Fault	Cause	Remedy
The display does not illuminate.	<ul style="list-style-type: none"> <li>• The control unit is not switched on.</li> </ul>	<ul style="list-style-type: none"> <li>• Switch the control unit on.</li> </ul>
	<ul style="list-style-type: none"> <li>• The power supply is not switched on.</li> </ul>	<ul style="list-style-type: none"> <li>• Switch the power supply on.</li> </ul>
	<ul style="list-style-type: none"> <li>• The mains cable is not connected.</li> </ul>	<ul style="list-style-type: none"> <li>• Connect the mains cable to the control unit and plug it in to the mains supply.</li> </ul>
	<ul style="list-style-type: none"> <li>• The fuse in the control unit is faulty.</li> </ul>	<ul style="list-style-type: none"> <li>• Replace the fuse.</li> </ul>
	<ul style="list-style-type: none"> <li>• Control unit, cables, connections, contacts, mains switch or sockets are faulty.</li> </ul>	<ul style="list-style-type: none"> <li>• Send unit and accessories to joke service for inspection or repair.</li> </ul>
Handpiece doesn't start.	<ul style="list-style-type: none"> <li>• Contacts are faulty.</li> </ul>	<ul style="list-style-type: none"> <li>• Check the handpiece connections.</li> <li>• Check the connections between the motor and its accessories.</li> </ul>
	<ul style="list-style-type: none"> <li>• Motor, circuit, cable, connections, contacts or sockets are faulty.</li> </ul>	<ul style="list-style-type: none"> <li>• Send unit and accessories to joke service for inspection or repair.</li> </ul>
The handpiece stops.	<ul style="list-style-type: none"> <li>• Automatic switch-off on idling</li> </ul>	<ul style="list-style-type: none"> <li>• Switch the handpiece back on</li> </ul>



***Brilliant solutions for perfect surfaces***

joke Technology GmbH  
Asselborner Weg 14 -16  
51429 Bergisch Gladbach  
Germany  
+49 22 04 839 0  
info@joke.de  
www.joke.de  
www.joke-technology.com

**Operating instructions order number: BA2085D**